

*H. L. Mc Nish,
Jointing Stares,*

No 17,130,

Patented Apr. 21, 1857.

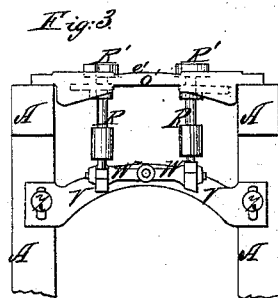
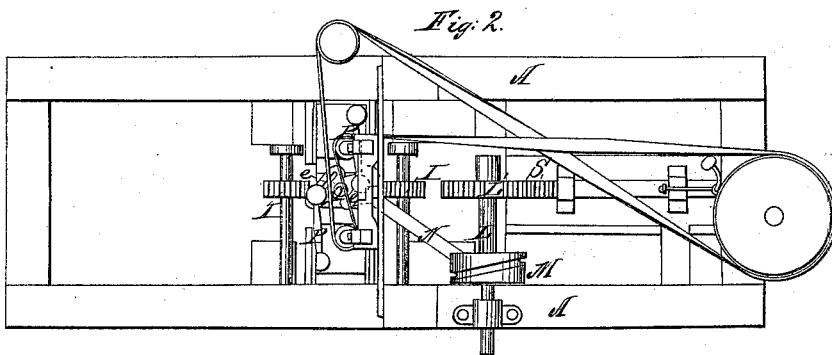
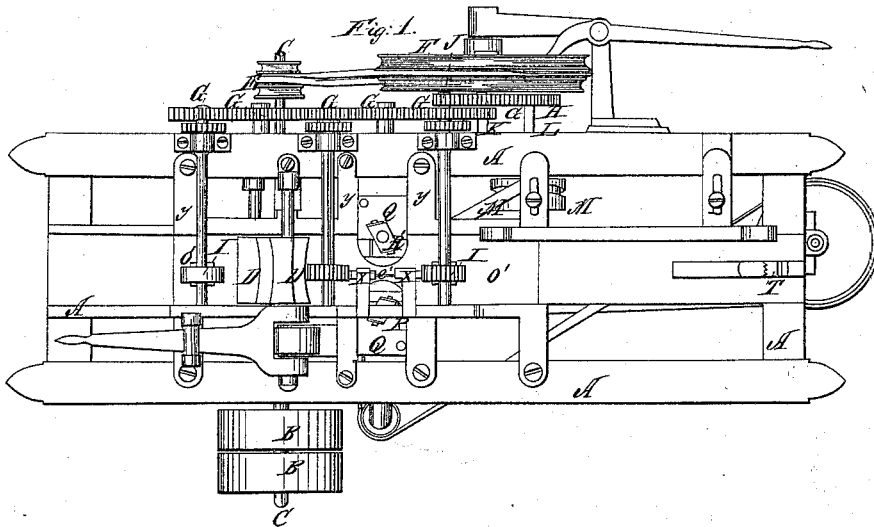

*Witnesses:
Dr. H. H. H. H.
Wm. S. S. S.*

*Inventor:
Henry L. Mc Nish*

UNITED STATES PATENT OFFICE.

HENRY L. McNISH, OF LOWELL, MASSACHUSETTS, ASSIGNOR TO H. L. McNISH AND D. C. BUTLER, OF SAME PLACE.

STAVE-MACHINE.

Specification of Letters Patent No. 17,130, dated April 21, 1857.

To all whom it may concern:

Be it known that I, HENRY L. McNISH, of Lowell, in the county of Middlesex and State of Massachusetts, have invented certain new and useful Improvements in Stave-Dressing Machines, of which the following description, illustrated by the accompanying drawings and references, is sufficiently clear and comprehensive to enable persons of competent skill to make and use my invention.

In my machine for cutting staves for barrels, casks, &c., I have so constructed the cutters, their attachments and the bed upon which the staves slide, that I can adjust and arrange all parts necessary to cut staves of different widths in the same barrel with both a bulge and bevel proportionate to the said width—and also with the same machine differently adjusted to cut staves for barrels, casks, &c., of all sizes and forms, all the staves being properly proportioned by the machine as above.

All the improvements here contemplated except the V which is claimed as a new device for guiding the stave—all refer to the arrangement and combination of parts by which a variety of bulges and bevels and cuts of the side of the stave may be made of uniform and scientific proportion in all respects—and suitably prepared at once, for the form, size, &c., of the work required—thus making the same machine adjustable to all the kinds of cut required for large or small wide or narrow barrels, casks, &c., to be made—and thus superseding the necessity of separate machines for each variety.

In the drawings—Figure 1, is a top view. Fig. 2, is a bottom view looking upward the drive wheel and its attachments being removed and Fig. 3 is a section showing the mode of hanging the vertical side cutters, &c.

A is the frame of the machine B the drums upon the drive shaft *c* from which shaft power is communicated to the horizontal cutters D, D' (one above, and the other below the flat side of the stave); and also from the band wheel E to F—both having variable speed grooves as represented from F, power is conveyed by the cogged gear wheels G, G, G, G, G, G, and their shafts, and from them to the friction press rollers I, I, I, for guiding the stave and

conducting it through the machine—these rollers being located in pairs above and below the machine bed in the usual manner. Power is communicated to H by means of J, (*k* being loose upon its shaft;) L, upon which is the wheel M, having a cam groove in its periphery as represented giving motion to the lever N, which is bent upward and hung in a fulcrum at O, and spreading out into a plate or foot in which are the slots *e, e*, for the purpose of adjusting the connections P, P, which hold and operate the slide bearings 2, 2, which form the bearings for the upper part of the vertical shafts R, R, to which the cutters R', R', are attached as represented. Upon the same shaft L, is a segment of a spur gear L' which upon each revolution of the shaft takes the rack S, and with it a claw T, which drives the stave, sufficiently far to be taken by the pressure wheels or rollers—this rack S, is then released from the intermittent spur and the weight U brings it back to its original position ready to take another stave when fed in by the tender.

It will be perceived by the arrangements of the slots *e, e*, and connections P, P, that as the connections are adjusted within the slot nearer to the center or fulcrum on which the lever N, turns a proportionably less variation will be given to the vertical cutter shafts R, R, by the action of the lever and cam wheel, and consequently a less bulge or more nearly straight stave;—the variation being in all cases in a ratio to the distance of the adjustment on the connections R, R, from said center or fulcrum; the slots *e, e*, in which the change is made being set at an angle of forty five degrees to the line of the connections should a greater variety of bulges on the same head diameter barrels or casks be required—a variety of cam wheels may be used to effect the object. But all the staves made with the above variety of bulges (the staves being assorted and one variety run through at a time) will have the same head diameter and consequently a proportionate bevel upon the edge of the staves, the cutter shafts being hung in bearings pointing to a center, varied only by the varying bulge as above specified to change the stave bevel to correspond with a different head diameter another adjustment becomes necessary. This adjustment is made by giving a greater

length to the cutter shafts R, R, by lowering the bracket B which supports the pin upon which the arms *w, w*, turn which arms hold the lower end of the shafts. These shafts are adjustable with the arms and are lengthened, the arms being brought down a distance corresponding to the fall of the bracket. The line of the vertical shafts R, R, being therefore changed with reference to the point on which they turn, (being the center on which the arms turn) the head diameter will be proportionally changed and again all the varieties of bulge and bevel may be again cut upon the new head diameters. It will however be observed that whenever a different head diameter is required by lowering the bracket V by the set screws *z, z*, in its slotted feet, as stated, a different curve for the bed of the stave will also be required. As the curve of the barrel will be changed to provide for this purpose I have constructed the cross bars, *y, &c.*, which connect the top of the frame and hold the bed plate so as to allow me to remove the bed at pleasure and substitute another in its place, having a curve corresponding to the curve of the stave required. By substituting different curves or bed plates O' in this manner I am enabled to provide them at a trifling cost, as I can put several at a time upon a cylinder and "turn them all up" in a lathe at once, and by hav-

ing several cylinders furnish the variety required a difficulty has been experienced in keeping the stave in a direct line in its course through the machine. To provide for this difficulty I have inserted in each bed plate a V rail or V guide as seen at *e'*, beneath the pressure rollers X X which effects the object in a very desirable and efficient manner.

The cutters for cutting and curving the sides of the stave are of the ordinary construction and may be varied in curve and cut in the ordinary manner.

P', P', are tightening pulleys which may be adjusted as represented or in any other convenient manner.

I claim—

1. The angular guides *e'* upon the lever N, in combination with the connections P P and concomitant parts for adjusting the side cutters R' R' to dress staves of different widths, and at the same time preserving the proportion between the bilge and the width of the stave as set forth.

2. I also claim the V guide *e'* on the bed plate for the purpose of guiding the staves in a direct line through the machine as set forth.

HENRY L. McNISH. [L. s.]

Witnesses:

JNO. B. FAIRBANK,
WM. SINCLAIR.